

6

THE DROID VOICEBOX

The Droid Voicebox is a descendant of the venerable talk box guitar effect. This is an effect made famous by Peter Frampton, who used an early model to make his guitar “talk” in his signature hits “Do You Feel Like We Do?” and “Show Me the Way.” (If you’ve tragically avoided these seminal Frampton hits, please take a moment to swing by YouTube and educate yourself.¹)

In a commercial talk box effect, a specialized speaker called a *compression driver* pumps the sound from the guitar into a tube that the musician holds in his or her mouth (I know this sounds nuts; please stick with me).

.....
1. Peter Frampton is the most egregious user of the guitar talk box, so the talk box has become synonymous with his 1970s good-time stoner brand of pop. But the effect is fairly widely used—often to more subtle effect. My favorite subtle applications include the lead guitar riff in Steely Dan’s “Haitian Divorce” and the opening of Bon Jovi’s “Livin’ on a Prayer.”

The guitarist is then able to use his or her mouth to sculpt the guitar riffs into flutters, wows, trills, and even fairly intelligible speech, which is picked up by a plain old vocal mic and then amplified.

The guitarist's talk box uses guitar licks as its sound source. We'll build a small square-wave oscillator to generate those sound waves and a homebrew compression driver to get them to our mouths. The result is a very inexpensive, quick-build "robot voice" effect. You'll sound sorta like Leia masquerading as the Ubese bounty hunter Boushh at the beginning of *Return of the Jedi*. Many folks initially mistake this effect for a much more expensive, trickier-to-build vocoder device.

In terms of build complexity, this project is designed with beginners in mind—especially those who've never worked with an *integrated circuit (IC)* before. The instructions assume no prior knowledge, and the components themselves are fairly robust, likely to weather the fumbles of folks new to soldering. These components are also all extremely common: any hobby shop that stocks electronic components will have the ones listed here, and the funnel, tubing, glue, and so on can be found at any hardware store. Expect the total cost to be less than \$20. If you order your electronic components online, or scrounge items like speakers and switches from broken toys and home electronics, you can substantially reduce that price tag. The Voicebox is also great for getting kids pumped about electronics because it (1) makes you sound like a robot and (2) demands you place foreign objects in your mouth and act goofy.

The finished Voicebox is shown in Figure 6-1. Wanna hear it before you build it? Check out samples at <http://www.nostarch.com/jamband/>.

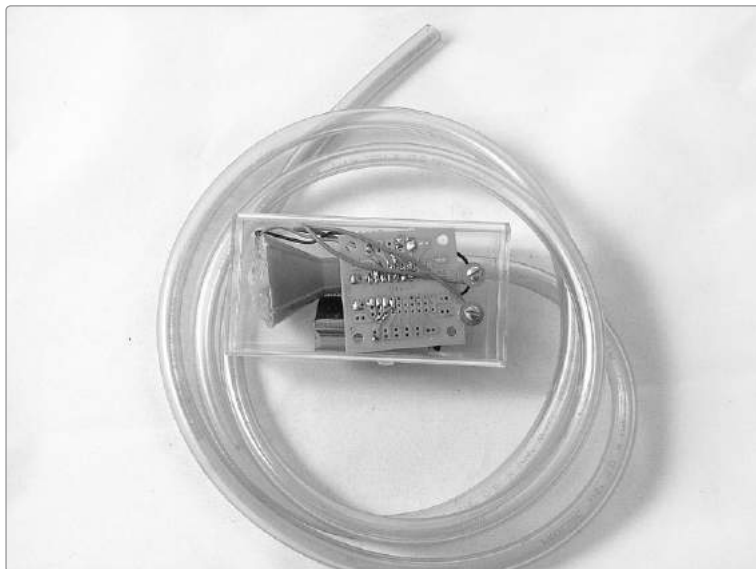

FIGURE 6-1: *The finished Droid Voicebox*

Preparation

Build Time

- ▶ About an hour, plus drying time

Tools

- ▶ A standard soldering kit (See page 340.)
- ▶ A saw (You'll be cutting a plastic funnel, so basically any old hacksaw, wood saw, keyhole saw, or jigsaw will do.)
- ▶ An electric drill with bits (You'll need 3/8-inch, 1/4-inch, and 1/8-inch bits.)
- ▶ A fine-point Sharpie or other permanent marker
- ▶ A small screwdriver, either flathead or Phillips—whichever matches your 4-40 machine screws
- ▶ Needle-nose pliers

Supplies

- ▶ An LM386 op-amp IC, such as Digi-Key part #LM386N-1/NOPB-ND (See "On the LM386" on page 74 for more information about selecting an op-amp IC.)
- ▶ An 8-pin IC socket
- ▶ A red LED
- ▶ A 470 ohm resistor (yellow-violet-brown stripes)²
- ▶ A 10k ohm resistor (brown-black-orange stripes)
- ▶ A 1k ohm resistor (brown-black-red stripes)
- ▶ A 100 μ F electrolytic capacitor
- ▶ A 0.1 μ F capacitor (marked *104*)
- ▶ A general-purpose IC PC Board (These instructions show RadioShack part #276-159. Some alternatives are listed in "Use a Different PCB" on page 93; if you choose the Adafruit 1/4-Sized Perma-Proto PCB, read "Building on Another Generic PCB" on page 239 before getting started.)
- ▶ A small 8 ohm speaker (I used RadioShack part #273-0092, which is roughly 1 1/8 inches in diameter, but you can also scrounge perfectly suitable speakers of this type from many toys.)
- ▶ An SPST pushbutton switch, such as Mouser part #103-1012-EVX or a non-illuminated doorbell button
- ▶ A 9-volt battery
- ▶ A 9-volt battery clip
- ▶ 24-gauge insulated wire (Either stranded or solid core wire is fine.)

.....
2. Resistor codes are discussed more fully in "Resistors: Fixed and Variable" on page 325.

- ▶ Two 1/4-inch-long 4-40 machine screws (Be sure they're long enough to go all the way through your case's wall; you might need 1/2-inch screws for a beefier enclosure.)
- ▶ Two 4-40 nuts
- ▶ Two 4-40 washers
- ▶ A plastic funnel (I used a 4-ounce funnel with a 3 1/8-inch inside diameter mouth and a 3/8-inch inside diameter throat, but there's room to improvise. Just make sure the mouth of your funnel can accommodate your little speaker and the throat will snugly hold your plastic tubing.)
- ▶ Several feet of flexible plastic tubing (I used about 4 feet of tubing with an outer diameter of 3/8 inch.)
- ▶ A small, sturdy, nonmetallic enclosure (You can buy a suitable project box at many hobby stores or use something you find around the house or garage. See "On Enclosures" on page 214 for more information.)
- ▶ Silicone-based household glue (This is also called *room-temperature vulcanizing rubber*, or *RTV-1*; the 1 means that it's in a single tube, instead of two tubes that you have to mix together.)
- ▶ A clean sheet of paper
- ▶ (Optional) 22- or 24-gauge bare bus wire (This is uninsulated solid core wire. Because you need only three little snips of bus wire for this project, you can get away with using a scrap of wire, a leftover bit snipped from a component lead, or even a piece of a paper clip.)

On the LM386

There are several versions of the LM386 with varying output power, differentiated by a suffix like *N-1* or *N-3* after the *LM386*. Brick-and-mortar hobby electronics stores tend not to differentiate these well, with the several variants all floating around together in the same bin for the same price. You'll typically find the LM386N-1 (Digi-Key part #LM386N-1/NOPB-ND), which drives an 8 ohm speaker at around 0.325 watts. But it's not unusual to find an LM386N-3 (roughly twice the output power; 0.7 watts at 8 ohms) or LM386N-4 (which puts out 1 watt at 32 ohms—that can amount to 4 watts at 8 ohms!). I've tested the N-1 and N-3, which operate within the same supply voltage range, and both work fine here. Droid Voiceboxes built around the LM386N-3 tend to have a slightly lower base pitch but are otherwise indistinguishable. I haven't tested this design with an LM386N-4, but it should work fine. The LM386N-4 also tolerates a slightly wider range of voltages, which can be handy in amplifier projects. Given the option, I'll grab an LM386N-3 or LM386N-4 when I can.

Building the Droid Voicebox

Step 1

First, familiarize yourself with the LM386 op-amp IC. The number one stumbling block in your first IC project is accidentally orienting the IC incorrectly in Step 1. You'll get to about Step 13 before you realize what you've done, and then the cursing starts. So, at the risk of being tedious, let's start slow.

Take out your LM386 op-amp IC (some folks generically call these *computer chips*, which is mostly inaccurate in this case) and place it on your clean sheet of paper. One end of the chip will be marked with a gray stripe, a little half-circle divot, a little circle near one corner, or all three. This can vary by brand, fabrication facility, or batch. Position the chip so that this marking is to the left; you should also be able to read any writing on the chip.

Next, number the IC's legs counterclockwise, beginning with the lower-left leg, as shown in Figure 6-3 (left). Note that in this orientation, the IC corresponds to the IC illustrated in the circuit diagram (see Figure 6-4). This is also how you view the IC if you're looking at a finished circuit but not how you look at the IC during many parts of the build, especially when soldering. Flip over the IC so that the notch that was on the left is now on the right and all the pins are sticking up like legs (i.e., dead-bug style). Now renumber the legs, going clockwise from the lower right, as shown in Figure 6-3 (right). This dead-bug view is how you see the IC while soldering and what you have to keep in mind throughout the build. You might want to label the second set of numbers *dead bug orientation* and keep it as a reminder on your workbench. Remember: you only solder to the dead bug.

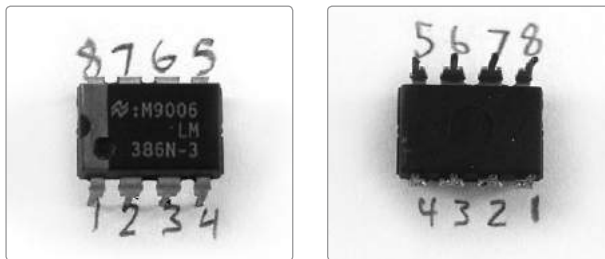

FIGURE 6-3: An LM386 with its legs numbered, in live-bug position (left) and dead-bug position (right).

Step 2

It's time to look at our schematic (shown in Figure 6-4). If this is your first time seeing a circuit diagram, don't fret. The thing to keep in mind is that a circuit diagram is a lot like a subway or bus route map: it doesn't show you how things are actually laid out in the physical world but instead shows you how the parts functionally connect to each other; in other words, it highlights the *scheme* that makes the circuit work. Figure A-28 on page 353 shows which component each symbol denotes.

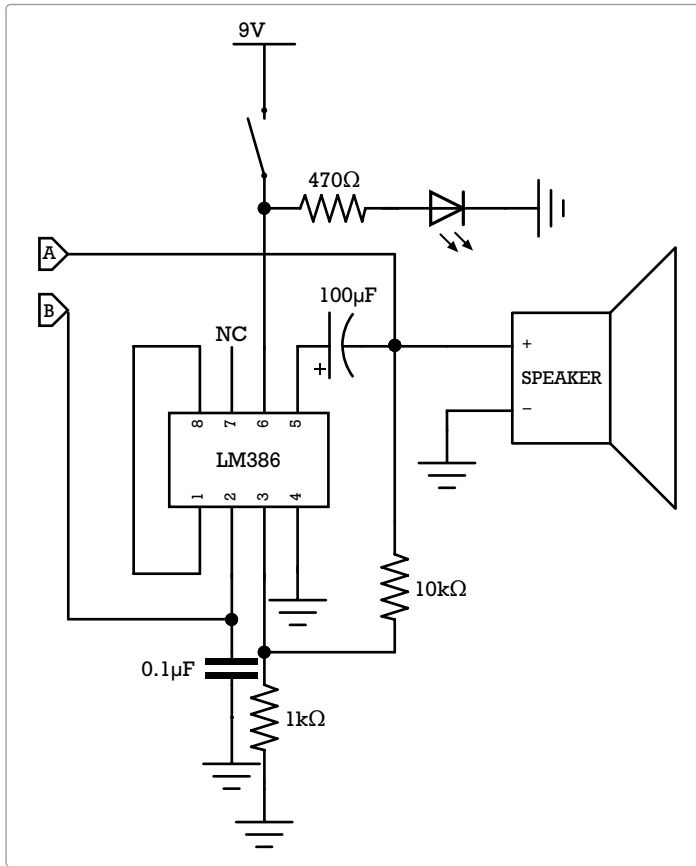

FIGURE 6-4: *The circuit diagram for the Droid Voicebox*

Connections in Circuit Diagrams

Throughout this book, I've done my best to make the circuit diagrams as clear as possible, which means, among other things, that I've avoided having lines cross unnecessarily. For the sake of clarity, I've followed the convention that crossed lines with a dot at the junction represent actual electrical connections. For example, see the right edge of Figure 6-4, where the speaker, a capacitor, a resistor, and a lead all come together. There's a dot at the junction because those elements are all wired together. Lines that simply touch without a dot—like the line connecting the body contact labeled *A* to the speaker, which crosses the line going from pin 6 to the power supply and switch—don't represent a connection.

Step 3

Let's start by mounting the IC socket on the *printed circuit board (PCB)*. The top of the PCB is plain, and the bottom has lots of shiny copper pads and traces. *Pads* are copper ovals and squares with one or more holes through their middles where you can solder the legs of components, and *traces* are the lines connecting various pads. Viewing the board from the top—that is, the side with *no* shiny copper pads or traces—slide the socket into the set of holes all the way to the left (see the left-hand image in Figure 6-5).

These sockets are technically symmetrical, but most models will have a little notch that corresponds to the stripe/notch/divot end of the IC. If your IC socket has a notch, then put that notch to the left. Holding the IC socket in place with one finger, flip the PCB over. You can bend one or more of the legs out to hold the PCB in place if it doesn't want to stay on its own. Set the PCB down and solder each leg to its solder pad.

The LM386 is a pretty hardy little guy, and it's highly likely that even a soldering newbie can join components directly to the IC without frying it. Nonetheless, it's good form to always socket your ICs for two reasons. First, plenty of ICs are easy to damage but costly to replace. Second, freakish things, like static electricity zapping an IC, do happen. The IC is basically the only component in this circuit that's liable to get damaged, so being able to easily swap it out might be quite a blessing someday.

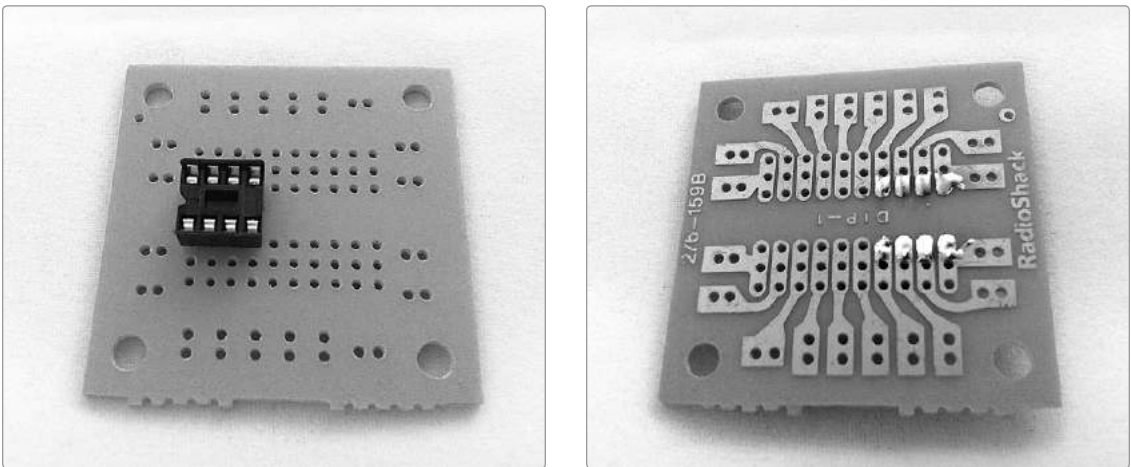

FIGURE 6-5: *The socket mounted on the PCB and soldered down, as viewed from the top (left) and bottom (right)*

Step 4

Next, we'll solder the jumper wires, which are little snips of bus wire connecting various points of the PCB. We'll start by connecting pins 1 and 8 on the IC socket. These are the top and bottom pins farthest to the left when viewed from the top. You'll be soldering from the bottom, however, so this first jumper is actually connecting the solder points farthest to the *right* in the right-hand image in Figure 6-6.

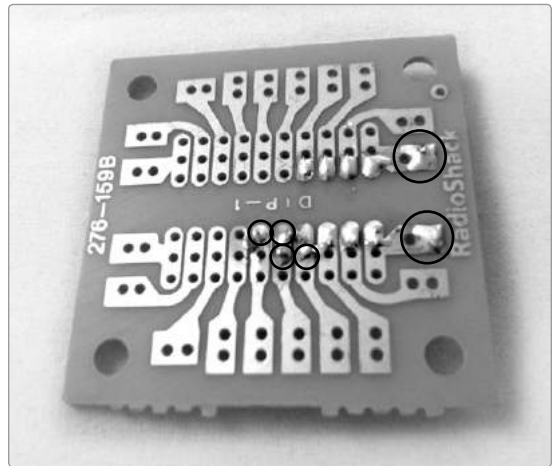
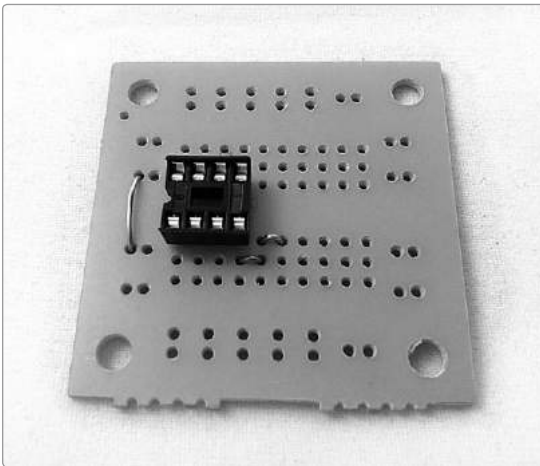

FIGURE 6-6: *Running the jumpers, as seen from the top and bottom. The solder joints added in this step are circled in the right-hand image. The PCB will quickly become crowded with solder points, so we'll use a clean diagram to show the solder points henceforth.*

You'll immediately see why I love this particular PCB: it makes it *really* easy for even the fattest fingers to connect lots of little components together without creating a snarl of short circuits. To connect pin 1 to pin 8, you'll need to snip a 1-inch length of bus wire (or a little chunk of a metal paper clip). Bend the wire into a flat-bottomed *U* and run it vertically between the two middle holes closest to the left edge of the PCB (as viewed from the top). This wire is the single vertical jumper shown in Figure 6-6, along the left edge of the PCB.

At this stage, we're also going to run jumpers for our *common ground*, which is the reference point and return path for electricity in the circuit. (For the purposes of all the circuits in this book, *ground* means the negative battery terminal.) Snip two more lengths of bare bus wire, each 1/2 inch long, and bend them into *U* shapes. Slip one into the open PCB holes at the tops of the two columns below and just to the right of the socket—that is, the fifth and sixth columns of holes on the lower half of the PCB. Run the other between the first open hole below pin 4 of the IC and the hole immediately to its right. This should be very clear once you see it; check out the overhead view of the PCB on the left side of Figure 6-6.

Flip the PCB over and solder these jumpers into place. (Bending the legs of the jumpers out prior to flipping will help hold them in place.)

Step 5

Now we'll prepare the two leads that will run to your Droid Voicebox's body contacts. Cut two 6-inch lengths of insulated wire, strip about 1/4 inch of insulation from one end of each, and tin these two bare ends. (If you're foggy on how to do any of this, flip to "Skills" on page 346.) Set aside one lead and then slide the tinned end of the other into the first open PCB hole below pin 2 on the IC (see Figure 6-7). Solder this wire in place.

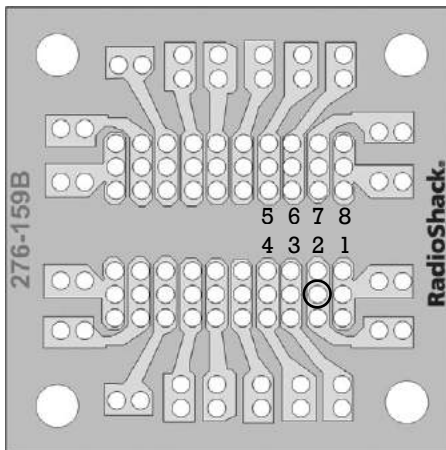
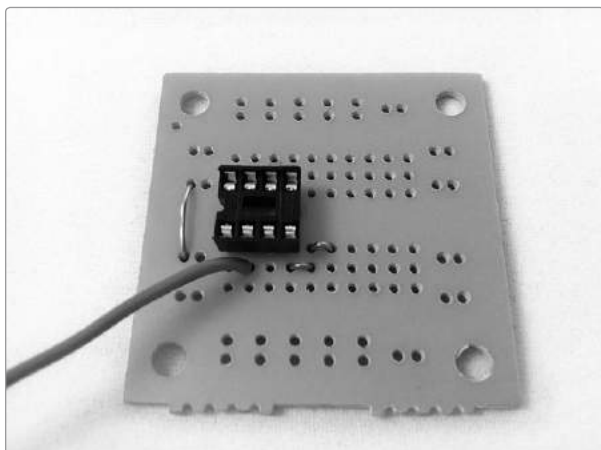

FIGURE 6-7: The first body-contact lead connects to pin 2. The image on the right shows the underside of the board, indicating the hole and solder pad for this connection; the numbers correspond to the pins on the IC.

Step 6

Our first capacitor is a little 0.1 μF ceramic disc capacitor, labeled 104. This sets the overall pitch range for the Droid Voicebox. Run one leg to the next open PCB hole below pin 2 on the IC and the other leg to the first open hole on the ground we designated in Step 4 (see Figure 6-8). Just as with the socket and jumpers, bending out the capacitor's leads after you mount it on the PCB will make it easier to keep it in place when you flip the board³—which you'll do now. Solder this cap at pin 2 (we'll solder all the grounds at once in Step 13).

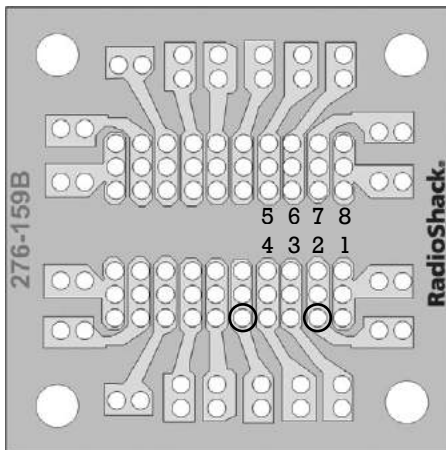
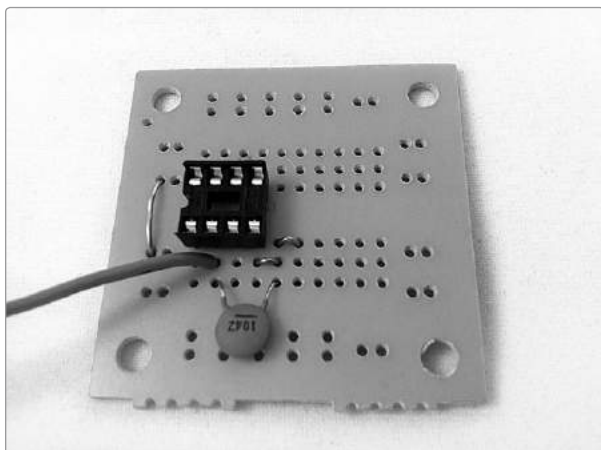

FIGURE 6-8: The 0.1 μF capacitor is ready to solder. The circles on the diagram (right) show the location of the capacitor legs; for now, you'll solder only the capacitor leg that lines up with pin 2.

3. This practice applies for pretty much any electronic component.

Step 7

Next, we'll install the other capacitor (that little blue barrel), which is a 100 μF electrolytic capacitor. Unlike the ceramic disk, this cap is polarized—the negative leg is marked with a black stripe. Run the positive (nonstriped) leg to pin 5 of the socket. Pin 5 is the IC's output, which is the upper-right pin when you view the chip from the top.

The capacitor's negative leg (the one with the racing stripe) goes to the top hole of the seventh column of PCB holes—that's the currently unused column to the right of the two ground columns we established in Step 4 (check out Figure 6-9 for clarification). Solder the capacitor leg connected to pin 5 of the IC but leave the other alone for now.

You'll note on the circuit diagram (Figure 6-4) that things get a little complicated between the IC's pin 5 output and the actual speaker. That's why we're running the negative leg of the cap over to its own column of holes—so we have plenty of room to wire up those connections.

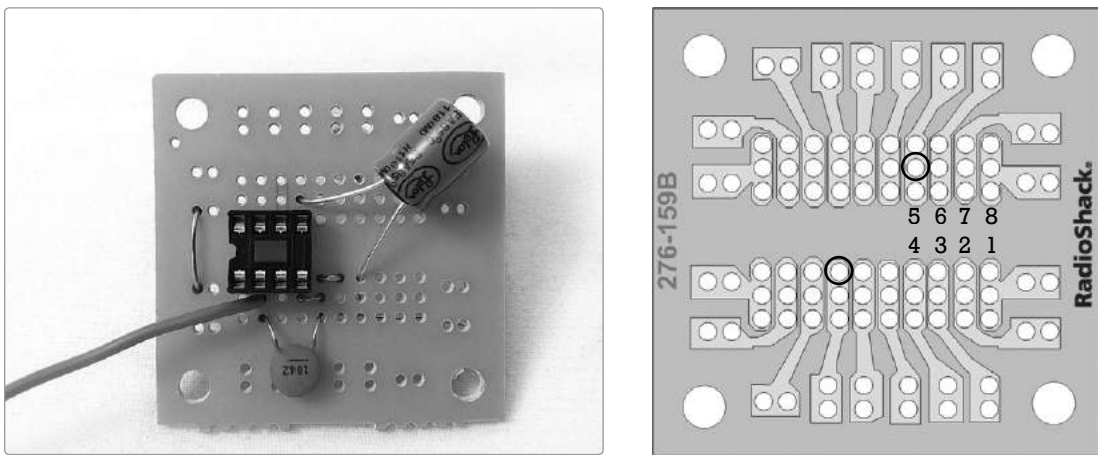

FIGURE 6-9: Placement of the 100 μF electrolytic capacitor

Step 8

Now we'll wire the IC's two resistors, which both connect to pin 3. The first is a 10k ohm resistor, coded with brown-black-orange stripes. (If you need details on reading resistor codes, flip to "Resistors: Fixed and Variable" on page 325.) This resistor runs from pin 3 of the IC to the negative leg of the 100 μF capacitor, but we're going to connect it in a tricky way to avoid short circuits and troubleshooting headaches.

See the parallel double row of holes along the bottom edge of the PCB? Run this 10k ohm resistor from the first hole to the last hole along the top row. The other resistor is 1k ohm (coded brown-black-red) and runs along the lower row, from the first hole to the second-to-last hole—that is, it runs from pin 3 to the ground we established in Step 4. Check Figure 6-10 for clarification if any of this is confusing (the 10k ohm resistor is above the 1k ohm resistor). Once the resistors are positioned, solder the two leads that connect to IC pin 3 but leave the other two alone; we'll solder the rest in later steps.

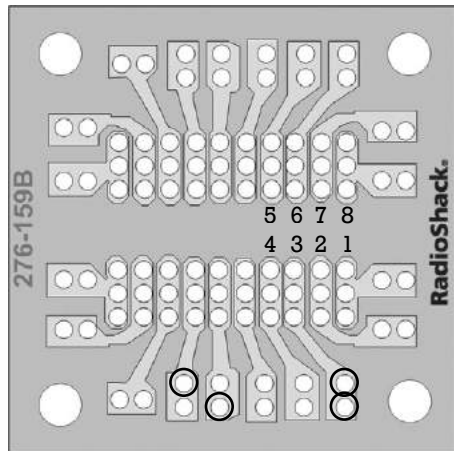
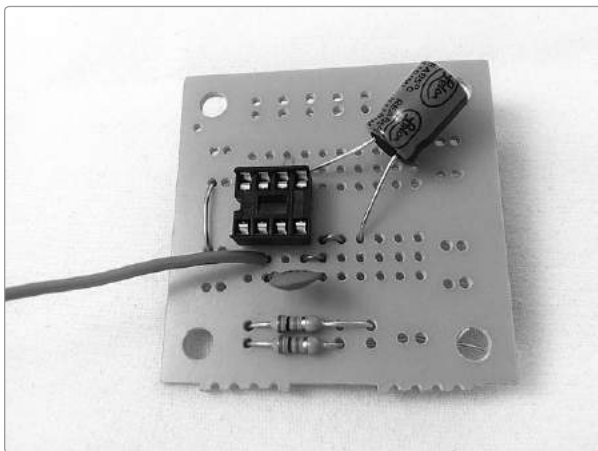

FIGURE 6-10: Placement for pin 3's two resistors; solder the two leads that share a copper pad now (that's the two circles all the way to the right in the underside-view illustration).

Step 9 Now it's time to finish off wiring up the output at column 7 on the PCB. Insert the other tinned body contact lead (prepared in Step 5) into the first open hole along column 7. (There should be a space right below the negative leg of the 100 µF electrolytic cap.) Then, take the positive lead from your speaker,⁴ strip away about 1/4 inch of insulation, tin the bare wire, and insert that into the next open hole. You can see all of this in position in Figure 6-11.

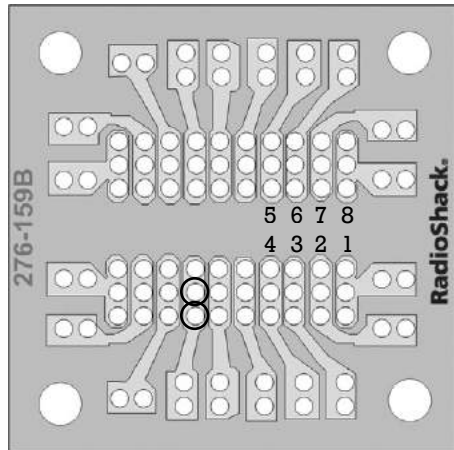
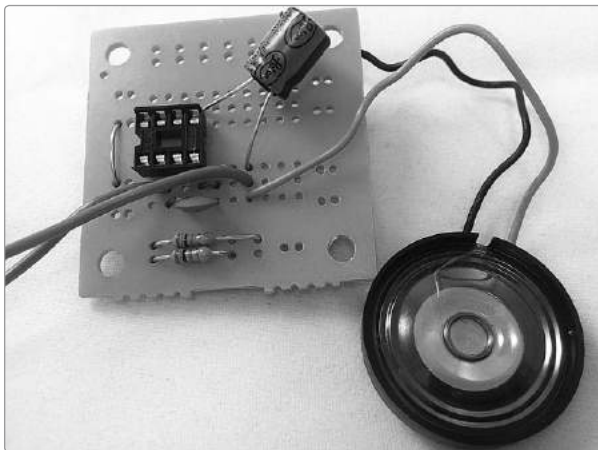

FIGURE 6-11: The output components are all in place. The underside diagram (right) highlights the placement of the second body contact and the positive speaker wire.

4. On many speakers, the two leads are basically interchangeable. If yours are differentiated (by either being different colors or being marked by a + or - sign), then you might as well honor that. The red lead is positive, as is the + sign.

Carefully flip the PCB over and solder all four wires at column 7: the negative electrolytic capacitor lead, the body contact, the positive speaker lead, and the other leg of the 10k ohm resistor.

Step 10 The LM386 op-amp takes power on pin 6, which we'll wire now. Technically, all you really have to do is insert the red lead from your battery clip into any hole in the column connected to pin 6 and then solder it down. However, if you do that, you'll have to pull the battery out when you aren't playing with the Voicebox, and you won't be able to get some transform effects.⁵ That's why we're getting a little more complicated and adding both a switch and an indicator light.

Start by shoving the PCB out of the way and digging out the 470 ohm resistor (coded yellow-purple-brown) and the LED. Solder the resistor to the positive leg of the LED (that's the one lead that's either a little longer, positioned opposite the flat-edge side of the LED, or—most likely—both). Figure 6-12 shows the prepared LED indicator light.

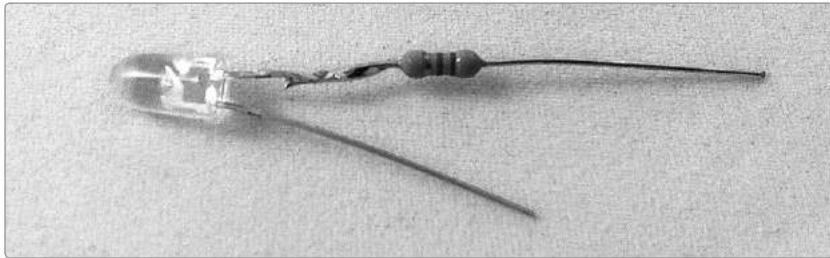

FIGURE 6-12: *Our indicator LED assembly*

*** NOTE:** *It's important to use a red or yellow LED here because we've chosen a resistor appropriate to the limitations of that color LED. An improperly buffered LED powered by a 9-volt battery can get really frickin' hot and even melt down. If you really want a different color here, that's totally doable, but flip to "The Gory Details: Voltage, Current, Resistance, and Ohm's Law" on page 330 and "Finding the Right Resistance" on page 331 because you might need a different resistor.*

Step 11 Because I've chosen a transparent case, I'm going to mount my indicator light right onto the PCB. This should also work fine for many other enclosures; you'll just end up mounting the PCB with the LED peeking out through a 1/4- or 3/16-inch hole in the case. Look at your case now and decide whether you need to add a couple lengths of insulated wire in order to place your LED where you want it. Either way, the resistor side of the indicator light assembly will go to the upper-left PCB hole, as shown in the right-hand image of Figure 6-13. The other, which is the LED's negative lead, goes to the first open hole in the ground connection. (For example, I had room at the second hole in column 6.) Solder the lead that's connected to pin 6—the one in that upper-left hole—and leave the ground lead to be soldered later.

5. For more on transforms and other neat little gating tricks, see "Playing the Scratchbox" on page 67.

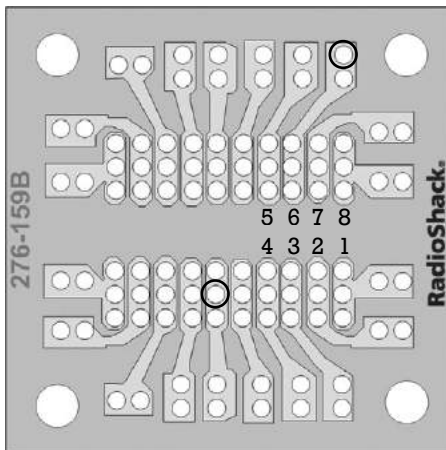
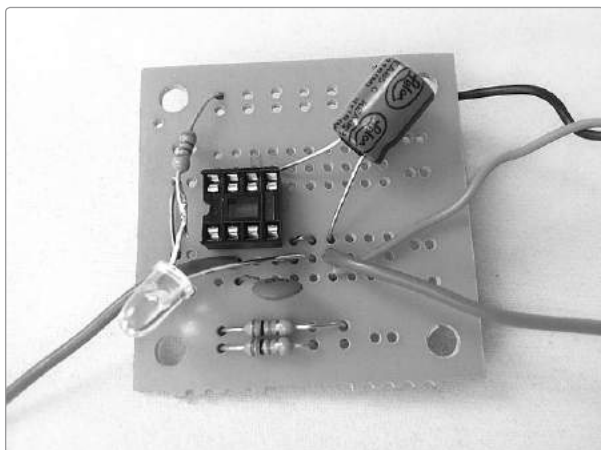

FIGURE 6-13: Placement for the indicator LED assembly

Step 12 Now for power! Take out your pushbutton SPST switch and the 9-volt battery clip. If you haven't already stripped and tinned the ends of the battery clip leads, do so now, removing about 1/4-inch of insulation. Then solder the red lead to one of the two terminals on your SPST switch. Now, cut a length of wire (probably less than 4 inches long, depending on your case), strip 1/4-inch of insulation from either end, tin both ends, and solder one end to the other switch terminal. The remaining end of this wire runs to the first open hole in the column connecting to pin 6 of the IC socket, as shown in Figure 6-14. Remember that, viewed from above, IC pins are numbered counterclockwise starting from the lower left (check Figure 6-3 for clarification)—so pin 6 is the third pin from the left on the IC's top row as viewed from the top.

Now, looking down at the circuit from the component side of the board, this wiring looks kinda crazy: we know from the circuit diagram that the LED's resistor-buffered lead goes straight to the power supply, but it's pretty obvious in Figure 6-14 that the LED's resistor and the power lead don't line up. But flip the PCB over, and you'll see how the copper trace for pin 6 snakes around and connects with that top corner hole in the PCB. Again, this is why I love this PCB for simple one-IC projects: it gives you plenty of space to work.

Now that we've got that clarified, feel free to solder that power connection to the PCB.

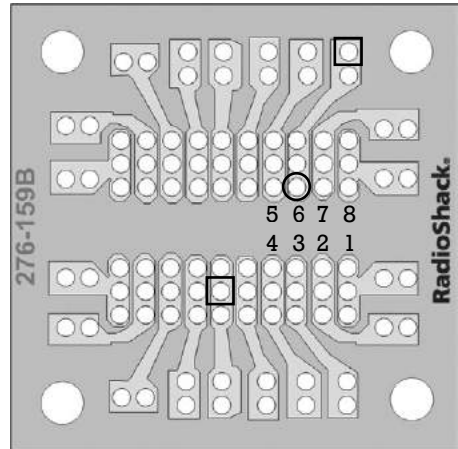
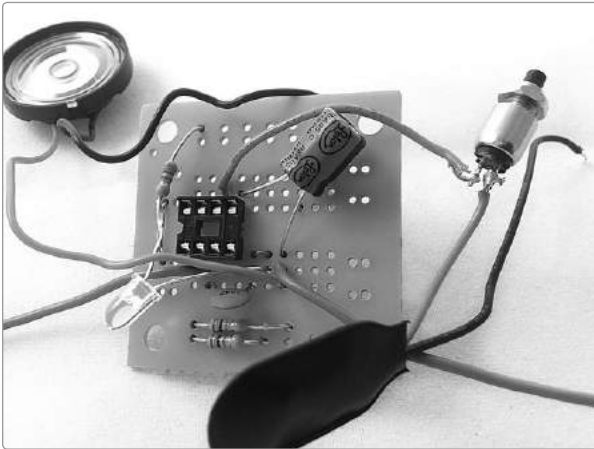

FIGURE 6-14: *We have power! The circle on the underside diagram (right) shows the power connection; the squares indicate the LED's connections.*

Step 13 Now we'll finish the circuit by soldering the common ground from Step 4, which occupies columns 5 and 6 of the PCB. There should be three loose leads there right now: one from the ceramic disk capacitor connected to pin 2, one from the 1k ohm resistor connected to pin 3, and one for the negative leg of the LED. Add the negative (black) lead from the battery clip and the loose lead from the speaker, which will share a hole with the 1k ohm resistor. Solder them all down. The completed circuit is shown in Figure 6-15.

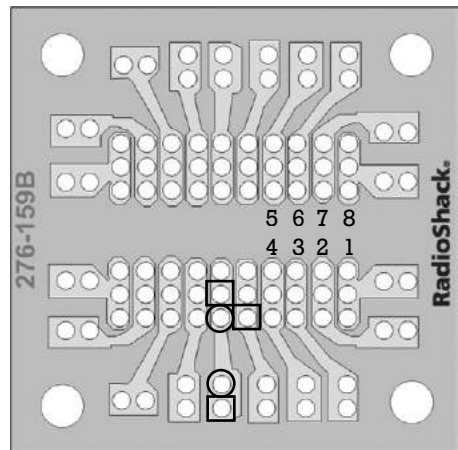
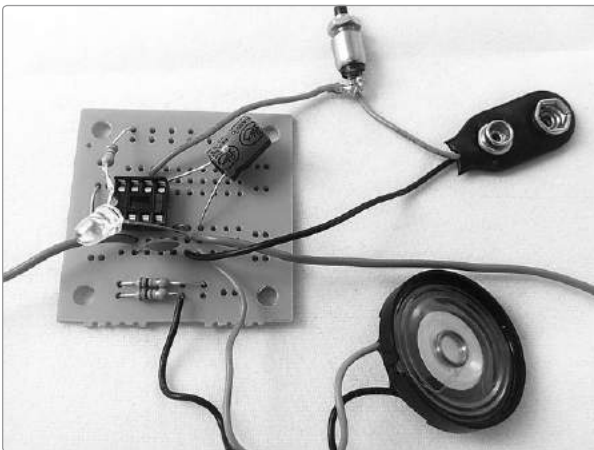

FIGURE 6-15: *The completed circuit (note that the IC hasn't yet been inserted). In the underside diagram (right), the squares indicate the three leads that have been waiting since prior steps to get soldered, while the circles show the two leads you just added.*

Step 14 Let's take this circuit for a test drive. Insert the LM386 op-amp IC into its socket, making sure that the stripe/divot/dot is to the left. Connect a fresh 9-volt battery to the battery clip and then strip about 1/2-inch of insulation from the loose ends of the two body contact leads. Next, hold those leads between your thumb and forefinger so that they *aren't touching!* Squeeze tight and push the pushbutton switch. The LED should come on, and the speaker should buzz or groan fairly loudly (it'll probably rattle around on the table like a jumping bean). Try adjusting how tight you're squeezing; this should alter the pitch of the tone.

If the LED lights but there's no sound, check to be sure the wires you're pinching aren't touching; your body acts as the final resistor the circuit needs to determine the pitch, and if you short the wires together, you'll likely get a pitch too high to hear. If there's no noise and no light, ask yourself, "Did I ignore the warning from Step 1 and build this whole stupid thing upside down?" If you're still having trouble, flip to "General Troubleshooting" on page 355.

Step 15 Once you have the noise-making circuit sorted out, it's time to add the funnel so that you'll actually be able to harness the funk of your Droid Voicebox. Start by slipping your speaker into your funnel so that the speaker's cone points straight into the throat of the funnel (in Figure 6-16, my left index finger is pressing the speaker into the funnel). Mark the location of the back of the speaker on the funnel (feel free to add 1/4 to 1/2 inch here, giving you a little extra funnel behind the speaker). For my 4-ounce funnel, this meant cutting off about 2 1/2 inches of the funnel, as measured from the rim of its wide mouth.



FIGURE 6-16: *Marking the funnel*

Step 16 Use your saw to cut the funnel at the line you drew in Step 15. *Be careful and go slow!* You're attempting to saw a straight slice across a cone; conic sections are advanced geometry, and this is an excellent opportunity to slip and cut yourself. If you're bothered by the rough edge left by the saw, you can smooth it out with medium-grit sandpaper (such as 100), a metal file, or a few stiff swipes along a concrete slab.

Step 17 For the Droid Voicebox to inject its racket into your mouth, you need a nice airtight seal around the speaker and funnel. Silicone-based household glue is basically the same as the clear caulk you might use around your bathtub or a leaky window. It makes a great seal and, as an added bonus, stays soft and rubbery, thus absorbing sound. This will help to minimize stray, unsculpted tones leaking from your Voicebox and distracting folks or mucking up recordings.

Place the speaker facedown into the funnel and give it a nice coating of glue all around the edge (an old pencil, chopstick, matchstick, or popsicle stick is great for applying this glue). Let the glue set up for a few minutes and then coat the entire back of the speaker with an even layer of glue for added sound insulation, as shown in Figure 6-17. Be aware that as you add glue, you may muffle the speaker, thereby decreasing overall volume even as you increase clarity. So you might want to pause, finish the enclosure, and then decide later whether you want to layer on more glue to tighten the seal.

This glue is usually tack-free (no longer sticky) in about half an hour, but it really needs to set for 24 hours to fully dry. Let it set undisturbed for at least half an hour before mounting everything in the case.



FIGURE 6-17: *The glued speaker with a pretty thick layer of insulating silicone*

Step 18 While you're waiting for the glue to dry, you can drill the holes in your case. Take out your enclosure and decide where you want to mount the two screws for the body contact leads, the pushbutton switch, and the talk tube. Mounting the body contacts and switch opposite each other on the front and back of the case makes for the easiest operation in my opinion, but you're welcome to mount these however you choose (see Figure 6-18, which shows a completed Droid Voicebox sans talk tube).

Drill two 1/8-inch holes about 1/2 inch apart, one for each body contact, and a single 1/4-inch hole for the pushbutton switch. You'll almost certainly want the talk tube to come out of the top of the unit because it needs room to connect to the funnel. If you've used the 3/8-inch tubing listed in "Supplies" on page 73, then drill a 3/8-inch hole in the top of the case for the tube (you can see the tube and how it connects to the funnel in Figure 6-20).



FIGURE 6-18: Note the opposing orientations of the body contacts (the two screws on the left face of the case) and the power switch (on the right face). You can also see the larger hole at the end of the case, which is for the talk tube.

Step 19 Now it's time to mount everything in the case. Slip the 4-40 machine screws through the 1/8-inch holes from the outside, place a washer on each screw, wrap a lead around each screw, and then tighten the nut down, as shown in Figure 6-19. The easiest way to tighten these screws is to hold the nut with your needle-nose pliers and use a screwdriver to turn the screw from the outside.

Install the pushbutton switch in the 1/4-inch hole. Carefully feed the talk tube through the big hole (for best operation this should be a fairly tight fit; if you've got lots of wiggle room, you'll probably want to seal around the edge of the tube using more silicone-based glue). If your speaker-funnel assembly is tack-free, then it's safe to carefully slide the tube into the funnel. This should be a really, really tight fit; if it isn't, then you *definitely* want to use some glue to caulk around the edges.

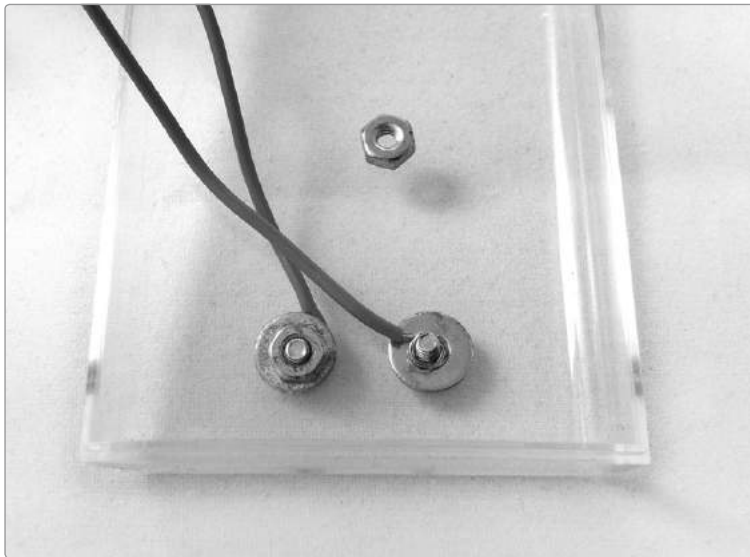

FIGURE 6-19: *Body contacts partially and fully installed, as viewed from the inside of the case. Note that the washer is on the inside of the case.*

Step 20 Once all of the glue is dry, slide the electronics into the case and close her up (see Figure 6-20). You are ready to funk out!

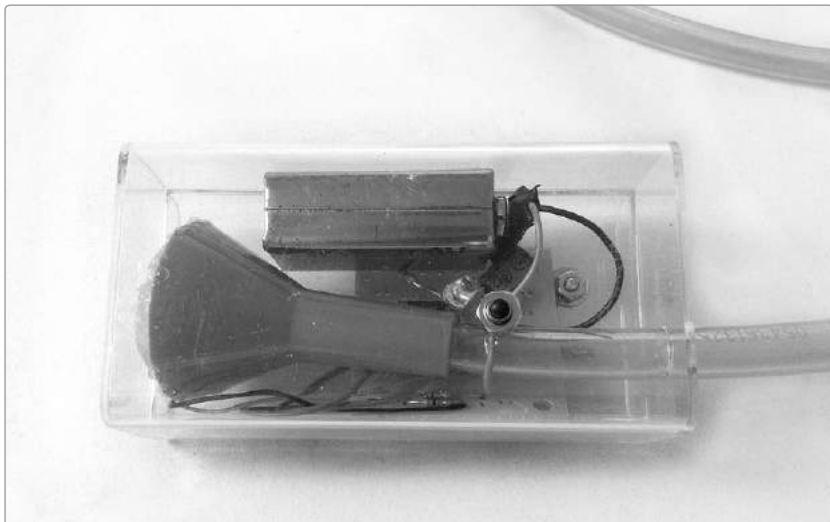

FIGURE 6-20: *The finished Droid Voicebox from a different angle, showing off our hacked-together compression driver*

Playing the Droid Voicebox

As you probably already noticed while testing the circuit, pushing the button activates the Droid Voicebox's square-wave oscillator, but you can only hear a pitch if you've also bridged the two body contacts with your fingers. This is because your body serves as the final resistor in the circuit. A light touch conducts poorly between the contacts, which translates to higher resistance and thus a lower pitch (perhaps so low a frequency that it sounds more like individual clicks than an actual continuous buzz). Pressing harder makes a better connection, which means lower resistance and thus a higher pitch.

To play the Droid Voicebox, place the tube in your mouth, lay a finger across those body contacts, and push the button to get a pitch. Start moving your lips, tongue, and jaw in order to “sculpt” that sound (very similar to the mouthings used when playing a harmonica, trumpet, or Jew's harp). Don't neglect the tube orientation, as this can have a profound impact on the sound.

In my experience, the most intelligible talking effect is achieved by laying the tube along the roof of the mouth (so it doesn't get in the way of the tongue) and closing off the larynx and nasal passage (in other words, hold your breath). Now get a buzz going and mouth some words. Start out with something that's largely defined by lip and jaw movements—such as “Bow-wow-wow yippie-yo yippie-yay!”⁶—and then work your way up to phrases that require more complicated tongue maneuvers. Words and phonemes that rely on back-of-mouth intonations will be the most challenging to achieve.

Using a microphone? Just sing into the mic as you normally would, but with the tube stuck in your mouth—which, yes, will feel awkward at first. By design, talk boxes (and this Voicebox) work excellently with all sorts of vocal mics, both for recording and in live performances. The long tube allows you to get great separation between the mic and the synth, massively reducing bleed-over. This unleashes your inner robot voice without subjecting your listeners to an annoying perpetual buzz.

Tips, Tricks, and Mods

The 0.1 μ F ceramic disk capacitor from Step 6 sets the overall pitch range for the Droid Voicebox, with the pitch going down as the value of that capacitor goes up. In my experience, a lower pitch gives a more intelligible talking effect, although a higher pitch range means more energetic sound waves and thus a higher apparent volume. But swapping the capacitor isn't the only great mod you can try.

6. With apologies and appropriate credit to George Clinton, the Parliament-Funkadelic Collective, Bridgeport Music Inc., Snoop Dogg, and any of the hundreds of other artists and corporate entities that might make substantive claims to the use of this phrase in robo-funk contexts of any sort.

Tweak the Body Contacts

Body contacts can be a little tricky because skin resistance varies a great deal by individual. It can be further complicated if you live in sweaty climates, have lotion on your hands, and so on. As a rule, a finger will give you between 3M ohms and a few hundred ohms of resistance, with younger skin putting up less resistance and older (and especially callused) hands a good deal more. If you're having trouble with responsiveness from the body contacts, consider bridging them with two or three 1M ohm resistors wired in *series* (that is, in a row, as in Figure 6-21; FYI, 1M ohm resistors have brown-black-green stripes). This puts the circuit right at (or just over) the threshold for producing an audible tone.

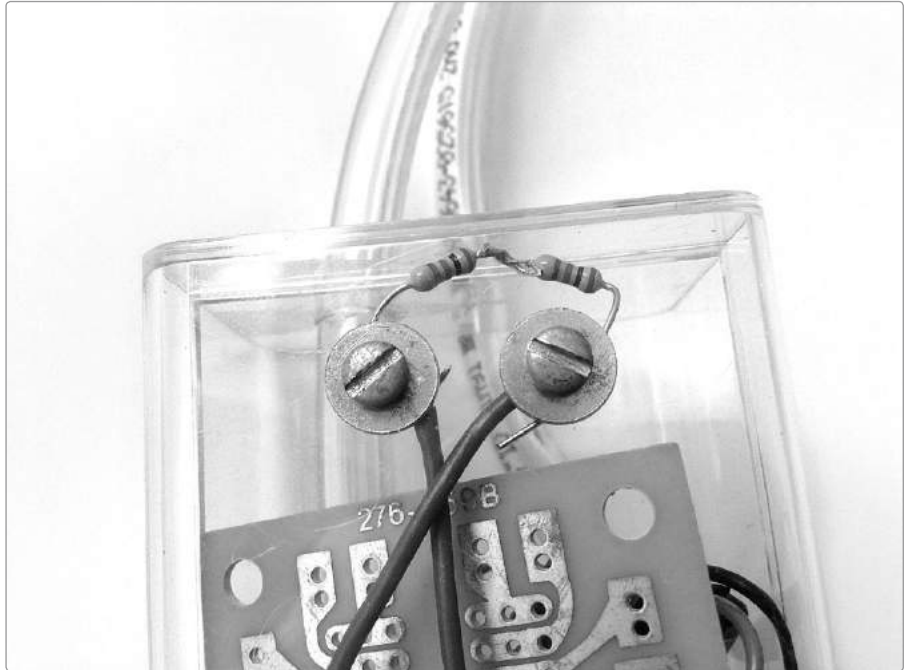

FIGURE 6-21: *A set of bridging resistors connect the body contacts, making it easier for my callused old hands to play the Droid Voicebox (the resistors are mounted inside the transparent case, with their leads sandwiched between the washers and nuts).*

Resistor Math: Series vs. Parallel

When resistors are connected in series—as in Figure 6-22—the same current passes through all of them. In order to calculate the *total equivalent resistance* for a set of resistors wired in series, you just add up the resistance of each individual resistor:

$$R_T = R_1 + R_2 + R_3 + R_4 + \dots$$

So, for example, by connecting two 1M ohm resistors, like the ones in Figure 6-22, we end up with a total of 2M ohms of resistance bridging the body contacts.



FIGURE 6-22: Series resistors (and the circuit diagram representing the same)

Resistors connected in *parallel*—like those in Figure 6-23—split the current. Their total equivalent resistance is calculated by adding together the *reciprocals* of each individual component's resistance:

$$\frac{1}{R_T} = \frac{1}{R_1} + \frac{1}{R_2} + \frac{1}{R_3} + \frac{1}{R_4} + \dots$$

If my thumb offers 1M ohms of resistance, then when I set it across the modded body contacts, it's in parallel with the 2M ohms' worth of resistors I have bridging the body contacts shown in Figure 6-21. Subsequently, you can find the total equivalent resistance from this expression:*

$$\frac{1}{R_T} = \frac{1}{R_1} + \frac{1}{R_2} = \frac{1}{1} + \frac{1}{2} = \frac{2}{2} + \frac{1}{2} = \frac{3}{2}$$

That result is the *reciprocal* of the total resistance, so flip it over and you have 2/3 of 1M ohm, which is something like 666k ohm—not a standard resistor you can just run out and buy at your local hobby store. This highlights the value of polishing up on your resistor math: it makes it possible to fake together resistances that either you don't have handy or can't actually get from a single store-bought resistor.



FIGURE 6-23: Parallel resistors

* If you're just running two resistors in parallel, there's a shortcut equation: $R_T = \frac{R_1 \times R_2}{R_1 + R_2}$.

Now when you lay your finger across the contacts, your body and the bridging resistors form a *parallel resistor network*. As a rule, the equivalent total resistance of such a network is always *less* than the resistance of the *smallest* resistor in the network, so even a light contact from a high-resistance thumb will be able to nudge the total resistance low enough for the circuit to start producing audible tones.

Alternatively, you can replace the body contacts altogether and instead use a 1M ohm (or higher) potentiometer (such as Mouser part #313-1000F-1M). Using a variable resistor in place of the body contact allows sure-fire pitches that are easy to dial in.

Use a Different PCB

Although I love the RadioShack General-Purpose IC PC Board (good ole part #276-159) for single-chip circuits like this one, it might not be the best choice, for one reason: RadioShack has significantly shifted its business model, and no longer has local stores in many smaller communities—which makes this little board less convenient to source. As noted at the beginning of this project, you have several alternatives to this RadioShack-specific PCB. First, you could purchase a clone: an increasing number of small suppliers have begun offering identical workalikes. Search online for *IC PCB Breadboard*, *experimenters breadboard 21-4595*, or *prototyping board 21-4595* for examples. As of this writing, MCM Electronics (<http://www.mcmelectronics.com/>) and SMC Electronics (<http://www.smcelectronics.com/>) consistently stock boards very similar to RadioShack's part #276-159.

Alternatively, if you're a slightly more experienced builder, you can use the schematic in Figure 6-4 as a guide and lay this circuit out on any generic pad-per-hole PCB. (Skim Project 11, the Mud-n-Sizzle Preamp, if you'd like to get a feel for working with a pad-per-hole circuit board.) Any of these generic grid PCBs will work fine: SparkFun PRT-08811, RadioShack's #276-148, Jameco part #105100, or Digi-Key part #V2025-ND. You could also get something larger, like Jameco part #2191445 or Mouser part #574-8015-1, and cut out a 2-inch-square piece to use for your Voicebox circuit.

Finally, I've prepared an alternative layout that will work on any breadboard-style PCB. These are designed to mimic the layout of a prototyping solderless breadboard (described in "Building a Circuit" on page 352), which makes it very easy to transfer an experimental test circuit to a permanent PCB.

I've used the Adafruit 1/4 Sized Perma-Proto PCB shown in Figure 6-24. It's a great board: reasonably priced, very well made, and very widely available online (you'll find a full list of sellers in "Guidelines for Sourcing Components" on page 323). For years, a slew of manufacturers have made comparable, if somewhat larger and clunkier, permanent breadboard-style PCBs (even RadioShack has one, part #276-170), so even if Adafruit stops making its 1/4 Sized Perma-Proto PCB, you'll still be able to use the layout shown in Figure 6-24.

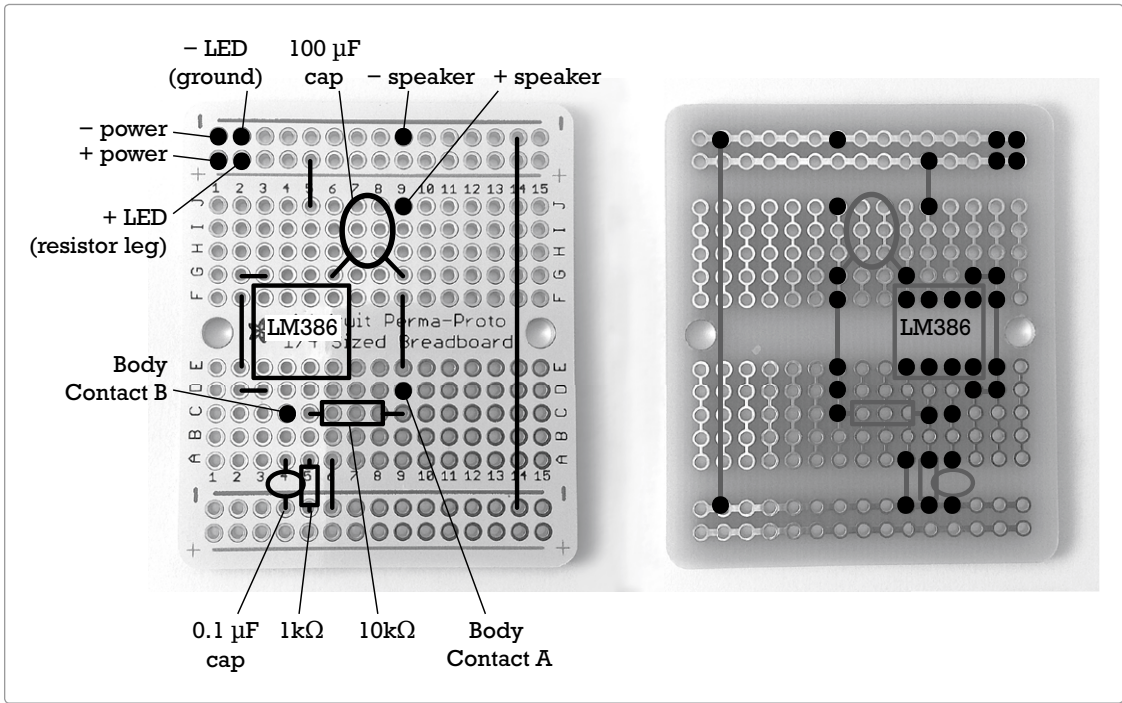

FIGURE 6-24: Top (left) and bottom (right) view of an alternative perma-proto breadboard layout for the Droid Voicebox. Unlabelled straight lines between solder pads are jumpers. I've highlighted the solder points on the right-hand image.

To build the circuit using this alternative layout, just go through the numbered steps listed in "Building the Droid Voicebox" starting on page 76, but use Figure 6-24 as your guide for placing the components on the PCB.